

Installation and maintenance guide

DAVtech

PRESSURE REDUCER DAT090-DAT092



DAV TECH SRL

Via Ravizza, 30 - 36075 Montecchio Maggiore (VI) - ITALY

Tel. 0039 0444 574510 - Fax 0039 0444 574324

davtech@davtech.it - www.davtech.it

Index

1 INTRODUCTION	pag. 3
1.1 The manual	
1.2 Warranty	
1.3 Goods receiving	
2 TECHNICAL DESCRIPTION	pag. 3
2.1 Pressure reducer operation	
2.2 Technical specifications	
3 INSTALLATION	pag. 3
3.1 Mounting on the machine	
3.2 Fluid connection	
3.3 Setting of the reducer	
4 MAINTENANCE	pag. 4
4.1 General rules	
4.2 Reducer Disassembly	
4.3 Reducer Re-assembly	
5 TROUBLESHOOTING	pag. 5
5.1 Problems and solutions	
6 BREAKDOWN AND DIMENSIONS	pag. 5
6.1 Overall dimensions DAT090 - DAT092	
6.2 Breakdown DAT090	
6.3 Components DAT090	
6.4 Breakdown DAT092	
6.5 Components DAT092	

1 INTRODUCTION

1.1 The manual

The user guide is the document that accompanies the pressure reducer from the time of its construction and throughout the period of use, it is therefore an integral part of the valve. It requires reading the manual before taking any action involving the valve. The manual must be readily available for use by staff and maintenance of the valve. The user and the attendant use are required to know the contents of this manual.

Reproduction of any part of this manual, in any form, without the express written permission of DAV Tech. The text and illustrations in this manual are not binding, the DAV tech reserves the right, at any time and without notice, the right to make any changes to improve the product or for reasons of character manufacturing or commercial.

1.2 Warranty

The warranty is valid for a period of 12 months from the date of commissioning and no later than 15 months from the date delivery. The interventions carried out during the warranty period does not extend in any way the validity period of the guarantee. The seller is not liable for defects caused by normal wear of parts which by their nature are subject to wear.

1.3 Goods receiving

The original configuration of the valve must never be changed.

Upon receipt of the goods, check that:

- The packaging is intact
- The exact correspondence of the material ordered.

2 TECHNICAL DESCRIPTION

2.1 Reducer operation

The DAT090 - DAT092 pressure reducer is a mechanical-hydraulic component designed to reduce and stabilize the pressure of medium to high viscosity fluid.

Its state at rest is normally closed, and by adjusting the load of the cup springs inside it, it is possible to set a determined and constant pressure of the outlet fluid, which can be viewed if desired by means of a pressure gauge mounted parallel to the output of the product.

2.2 Technical specification

Model	DAT090A	DAT090B	DAT090C	DAT092
Weight		3,5 Kg		3 Kg
Max inlet pressure		300 bar		90 bar
Outlet pressure range	10-60 bar	20-120 bar	30-180 bar	5-15 bar
Threads		1/4 G		

3 INSTALLATION

3.1 Mounting on the machine

The pressure reducing valve DAT090 - DAT092 can be mounted using the fixing bracket mounted on the head of the reducer itself, mounting in a vertical position is recommended.

Installation and maintenance guide

3.2 Fluid connection

The valve must be inserted in a hydraulic circuit, connected on one side to a pneumatic pump, while the output will be connected to one or more metering valves. Be careful to choose connection pipes suitable for the application and resistant to high pressures, as well as to cut and at least in part heat.

3.3 Setting of the reducer

The pressure regulator controls the pressure downstream of its product outputs. For correct operation, the fluid inlet pressure must always be greater than that of the outlet fluid, possibly in a ratio of at least 2: 1. When it is necessary to reduce the pressure, activate the trigger of the gun or the opening device of the user equipment, to discharge the pressurized fluid downstream of the reducer and ensure a correct reading of the value.

Adjust the supply air to the pump and control the regulator to ensure the optimal combination of the parameters required for use.

1. With the fluid supply line to the closed regulator, reset the regulator pilot air pressure. Turn the adjusting knob clockwise, in manual operated models.
2. Open the fluid supply line to the regulator.
3. Increase the fluid pilot pressure or turn the adjusting knob clockwise, in manual operated models, until the fluid outlet pressure from the regulator is at the desired level.

NOTE: In this type of device, regulation should always be carried out by operating "increasing".

4 MAINTENANCE

4.1 General rules

Thanks to the construction methods and the materials used, the DAT090 - DAT092 reducer is easy to maintain. A minimum, simple, accurate and constant maintenance allow a long lasting and regular operation of the product, keeping its performances unchanged.

4.2 Reducer disassembly

Before dismantling the reducer:

- 1) Clean it externally
- 2) Release the pressure from the system
- 3) Unscrew the Allen screws on the upper part
- 4) Unscrew the cup spring loading / unloading screw
- 5) Remove the various parts and clean them carefully

4.3 Reducer Re-assembly

After having cleaned it thoroughly and replaced all the damaged parts (above all the seals and the ball seat). Reassemble in the reverse order of disassembly by lightly lubricating the parts and gaskets with mounting grease.

5 TROUBLESHOOTING**5.1 Problems and solutions**

The search for possible malfunctions must only be performed by qualified personnel in compliance with the relevant safety regulations.

PROBLEM	POSSIBLE CAUSE	SOLUTION
Outlet fluid pressure drop	Locking ball on the seat - passage obstruction	Disassemble and clean
	Air leakage from the pilot air supply circuit (where present)	Check pilot air connections and pipes
The fluid outlet pressure increases up to the fluid inlet pressure level	The valve ball and seat are worn or locked. Membrane breakage	Clean ball and seat. Replace damaged or worn parts.
Fluid leakage from the regulator body or fluid rising from the pilot air inlet	Membrane breakage	Replace membranes

6 BREACKDOWN AND DIMENSIONS**6.1 Overall dimensions DAT090 - DAT092**

The dimensions change depending on the selected pressure setting.

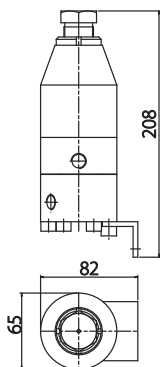
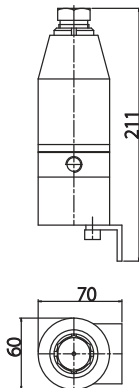
**DAT090****DAT092**

Installation and maintenance guide

6.2 Breakdown DAT090

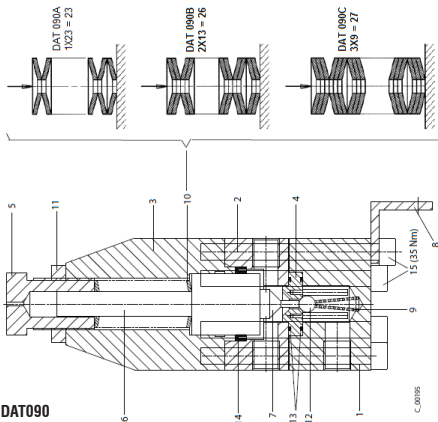

6.3 Components DAT090

DAT 090 PRESSURE REDUCING PART NUMBERS

Position	Description	Quantity	Code
1	Reducer lower body	1	DAB589.22
2	Reducer central body	1	DAB590.22
3	Reducer upper body	1	DAB591.22
4	Sphere seat	11	DAT6044.00
5	Adjustment screw	1	DAB594.03
6	Shutter piston	1	DAB595.53
7	Dipstick shutter	1	DAB619.03
8	Support	1	DAE506.62
9	Valve spring	1	DAH218.03A
10	Cup Spring	Look Breakdown	DAH266.02
11	Ferrule M25	1	DAK303.62A
12	Sphere	1	DAK813.04
13	Gasket Oring	2	DAL149.06
14	Gasket Oring	1	DAL418.08
15	Screw TCEI 8x90	6	DAK139.62
	Gasket Set		DAT9062.00

6.4 Breakdown DAT092

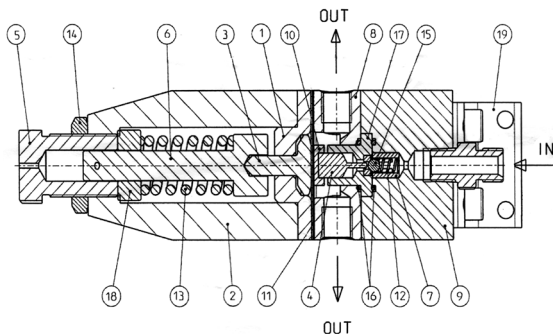

6.5 Components DAT092

DAT 092 PRESSURE REDUCING PART NUMBERS

Position	Description	Quantity	Code
1	Flange	1	DAB145.12
2	Reducer upper body	1	DAB147.12
3	Piston	1	DAB148.03
4	Dipstick shutter	1	DAB391.03
5	Adjustment screw	1	DAB594.03
6	Spring guide	1	DAB634.52
7	Sphere guide	1	DAB637.03
8	Reducer central body	1	DAB639.03
9	Reducer lower body	1	DAB640.03A
10	Membrane disk produced	1	DAB641.03
11	Intermediate membrane	2	DAG760.07
12	Spring	1	DAH261.03
13	Spring	1	DAH270.02
14	Ferrule	1	DAK303.62A
15	Sphere	1	DAK828.04
16	Gasket or	2	DAL130.06
17	Sphere seat body	1	DAT6008.00
18	Spacer spring/	1	DAB0655.03
19	Reducer support	1	DAE506.62
	Gasket set pos.11, 12, 16	1	DAT9061.00

DAV TECH SRL Via Ravizza, 30 - 36075 Montecchio Maggiore (VI) - ITALY - Tel. 0039 0444 574510 - Fax 0039 0444 574324

davtech@davtech.it - www.davtech.it

We reserve the right to modify at any time, without notice, the specifications, dimensions and weights in this manual.
The illustrations are not binding.