

Installation and maintenance guide

DAVtech

SPRAY VALVE DAS 200



DAV TECH SRL

Via Ravizza, 30 - 36075 Montecchio Maggiore (VI) - ITALY

Tel. 0039 0444 574510 - Fax 0039 0444 574324

davtech@davtech.it - www.davtech.it

Index

1 INTRODUCTION	pag. 3
1.1 The manual	
1.2 Warranty	
1.3 Goods receiving	
2 TECHNICAL DESCRIPTION	pag. 3
2.1 Valve operation	
2.2 Technical specifications	
2.3 Connection diagram	
3 FUNCTIONAL DESCRIPTION	pag. 4
4 INSTALLATION	pag. 5
4.1 Assembly	
4.2 Hose installation	
4.3 Installation instructions	
4.4 Putting into operation	
5 OPERATION	pag. 7
5.1 General and safety instructions for operation	
5.2 Operating instructions	
5.3 Switching on	
5.4 Switching off	
5.5 Shutdown	
6 MAINTENANCE AND SERVICING	pag. 9
6.1 Safety instructions	
6.2 Cleaning	
6.3 Servicing	
6.4 Changing the nozzle and nozzle needle	
6.5 Replacing and adjusting the nozzle needle	
7 FAULTS	pag. 13
7.1 General and safety instructions in relation to faults	
7.2 In the event of a fault	
7.3 Spray patterns/types of problem	
8 DIMENSIONS	pag. 15
9 BREAKDOWN	pag. 16

1 INTRODUCTION

1.1 The manual

The user guide is the document that accompanies the valve from the time of its construction and throughout the period of use, it is therefore an integral part of the valve. It requires reading the manual before taking any action involving the valve. The manual must be readily available for use by staff and maintenance of the valve. The user and the attendant use are required to know the contents of this manual.

Reproduction of any part of this manual, in any form, without the express written permission of DAV Tech. The text and illustrations in this manual are not binding, the DAV tech reserves the right, at any time and without notice, the right to make any changes to improve the product or for reasons of character manufacturing or commercial.

1.2 Warranty

The warranty is valid for a period of 12 months from the date of commissioning and no later than 15 months from the date delivery. The interventions carried out during the warranty period does not extend in any way the validity period of the guarantee. The seller is not liable for defects caused by normal wear of parts which by their nature are subject to wear.

1.3 Goods receiving

The original configuration of the valve must never be changed.

Upon receipt of the goods, check that:

- The packaging is intact
- The exact correspondence of the material ordered.

2 TECHNICAL DESCRIPTION

2.1 Valve Operation

The manual spray valve DAS 200 is designed to spray various kind of fluids.

The ergonomic handgrip and its weight make it very easy to handle and use, and the operator can focus on the process.

The valve DAS 200 can be equipped with various kind of extensions to have anytime the right dispensing result.

2.2 Technical Specification

Model	DAS 200
Drive	Manual
Weight	240g
Fluid pressure	Max 4 bar (standard version) Max 25 bar (HP version)
Atomizing air pressure	0,5 - 6 bar
Air inlet	Tube 6x4mm
Fluid inlet	Tube 6x4mm (standard version) - Fitting ¼ gas (HP version)
Air cap	Tube 6x4mm
Fluid adjustment	Micrometric
Materials	Stainless steel and aluminium
Fluids to be dispensed	Oil, lubricants, release agents, grease and pasty products (HP Version)

2.3 Connection diagram

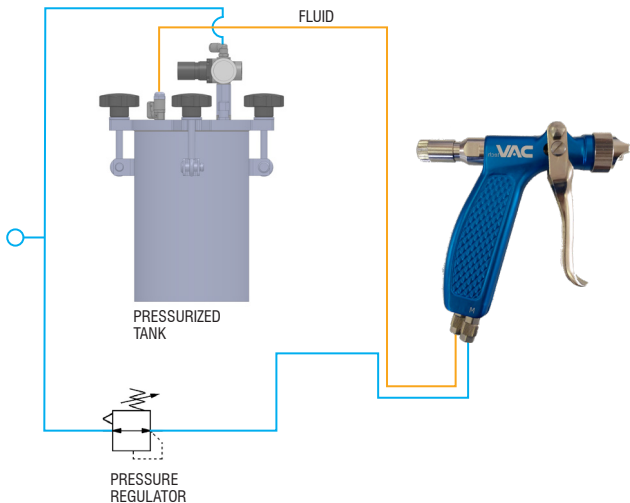

3 FUNCTIONAL DESCRIPTION

The DAV 200 spray gun is suitable for the extremely fine application of thin, liquid media, such as paints or release agents within a pressure range of 50 bar material pressure. Depending on which air cap is used, the output may be round or flat.

The desired application pattern depends on the viscosity of the medium being applied, and can be modified individually and adjusted by means of the nozzle size, air cap, atomising air pressure and material pressure.

The material and air are fed in via connections on the body of the handle.

When the trigger is operated, the needle is pulled out of the nozzle, which allows the material to escape from the nozzle. When the trigger is released, the needle is pushed back into the nozzle by the built-in needle spring, which interrupts the emergence of the material.

The function of the needle is: to open in response to muscular force and to close in response to spring pressure. The spray gun is closed by the needle spring when the trigger is released.

4 INSTALLATION

4.1 Assembly

The manual spray valve DAS 200 can be used in any position.

The distance between nozzle opening and application level depends on the required application width of the material. The greater the distance between nozzle opening and application level, the greater the application width of the material.

4.2 Hose installation

Material is supplied to the spray valve via a separate connection. The connection ports are differentiated as follows:

- Material (transparent or white) Connection M: to pressure tank or pump
- Air (blue): Connection AIR for compressed air supply.

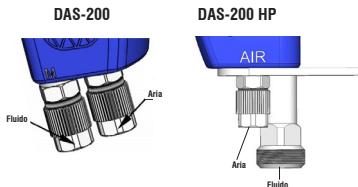

- IMPORTANT!**
To prevent malfunctions and damage to the manual spray valve and machine or plant, it is essential to ensure that the pressure lines are re-connected up to the correct hose connections on the spray valve.

- WARNING! RISK OF INJURY!**
It must be ensured that the spray gun is adequately grounded via a conductive air hose, and is connected into the potential equalisation system. (maximum resistance 10 Ω)

- WARNING! RISK OF INJURY DUE TO COMPRESSED AIR AND MATERIAL PRESSURE!**
Only qualified personnel may work on the pressure plant in accordance with the safety regulations. When working on the pressure plant, be sure to:
- Depressurise the plant before beginning work.
 - Not remove or disable safety equipment.
 - Not set pressures above the maximum permitted values.
 - Install all hoses safely so that the pressure lines cannot be damaged by moving machine or plant components.
 - Not put the pressure plant into operation until work is completed.

Hose installation:

Material connection:

1. Ensure that the screw connection is securely anchored to the spray gun !

Important: Other connections must be correctly assembled!

Air:

1. Unscrew the retaining cap from the screwed connection and push it over the hose.
2. Push the open hose end onto the connection port on the screwed connection.
3. Screw the retaining cap back onto the screwed connection and tighten.

- IMPORTANT!**
Only hoses which can withstand the maximum working pressure of the pressure line may be used.

Installation and maintenance guide

4.3 Installation instructions

The search for defects in the operation should be performed only by personnel qualified respecting the safety rules in force.



WARNING! RISK OF INJURY!

To prevent personal injury and/or property damage, it is essential to observe the following when installing the device in a machine or plant.

The device must be installed in a machine or plant in such a way as to rule out hazards like:

- > the escape of high-pressure fluids
- > defects in the compressed air supply
- > malfunctions of the device, machine or plant
- > failure or malfunction of plant control
- > loud noises or interference with acoustic signals

in the vicinity. To protect persons working on the device, machine or plant, effective safety devices and warning signs must be put in place. In addition, relevant safety instructions must be incorporated into the Operating/Installation Instructions for the machine or plant.

4.4 Putting into operation

The search for defects in the operation should be performed only by personnel qualified respecting the safety rules in force.



WARNING! RISK OF INJURY!

Only trained qualified personnel may put the machine or plant into operation in accordance with the safety and accident prevention regulations.



WARNING! Danger from material and substances!

There is a risk of coming into contact with or absorbing coating substances and/or cleaning fluids. There is also a risk of inhaling fumes from fluids. Under some circumstances, this can cause lasting damage.

Always wear personal protective equipment when working on the device!

Make sure there is enough forced or natural ventilation.

Obtain medical advice if symptoms are noted!

Observe the following before putting the machine or plant into operation:

- > Ensure that no tools or other foreign bodies are inside the machine or plant.
- > Check that the device and all other parts are secure.
- > Check that all pneumatic connections are on the correct ports and are secure.
- > Check that the set pressures correspond to the ratings and connection values of the device.
- > Check that safety devices are working.

1. Switch on power supply.
2. Switch on material flow.
3. Turn on device at plant controller.
4. Check that device is functioning and operating correctly.
5. Check that device is within all the specified set value ranges.

Once it has been established that the device is functioning perfectly, the device may be operated in accordance with all accident prevention regulations.

5 OPERATION

5.1 General and safety instructions for operation

To prevent disruptions, device function must be checked regularly by trained supervisors.

IMPORTANT!

In the event of faults or irregularities, shut down the plant immediately and inform the local person in charge.

If device faults cannot be corrected (see chap. 7 "Faults"), inform the manufacturer's Customer Service.

Only deploy instructed personnel for regular cleaning.

The device presents the following hazards during operation:



WARNING! RISK OF INJURY!

Danger from the device spraying out high pressure fluids. Always wear personal protective equipment when working on the device!



WARNING! RISK OF INJURY!

Hearing damage may result from the volume and length of exposure to noise. Wear ear protection when working with the device!



WARNING! RISK OF INJURY!

Housing parts with sharp edges and pointed corners can cause skin abrasions. Wear protective gloves when working on the device!



WARNING! WARNING! DANGER FROM MATERIAL AND SUBSTANCES!

**There is a risk of coming into contact with or absorbing coating substances and/or cleaning fluids. There is also a risk of inhaling fumes from fluids. Under some circumstances, this can cause lasting damage. Always wear personal protective equipment when working on the device!
Always wear personal protective equipment when working on the device!
Make sure there is enough forced or natural ventilation.**

Installation and maintenance guide

5.2 Operating instructions



WARNING! DANGER!

If the spray parameters are not adequately adjusted, there is a risk of inhalation, contact with or absorption of coating substances or cleaning fluids. Always wear personal protective equipment when working on the device!

- > If the material is kept pressurised with no contact with the outside air, it can remain in the valve during long periods without operation.
- > Only clean, filtered material may be used.

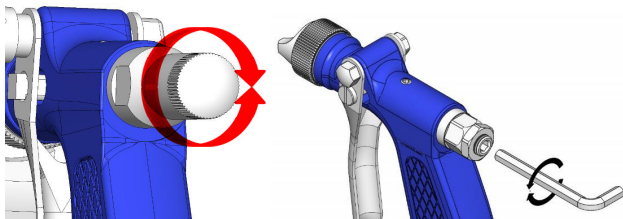

NOTE:

The flow of material can be adjusted to suit individual requirements by turning the regulating screw / spindle:

Turn screw to the right:  to reduce the material flow

Turn screw to the left:  to increase the material flow

NOTE:

The illustrations in these instructions may differ slightly from the actual version of the device. Incorrect handling can damage the nozzle and nozzle needle. Only reduce the material flow (by turning the regulating screw to the right) while the material is being dispensed. Once the nozzle closes, do not turn the regulating screw any further to the right.

5.3 Switching on

To prevent disruptions, device function must be checked regularly by trained supervisors.



WARNING! RISK OF INJURY!

Only trained qualified personnel may switch the device on and off in accordance with the safety and accident prevention regulations.

1. Switch on power supply.
2. Switch on material flow.
3. Turn on device at plant controller.
4. Check that device is functioning and operating correctly.
5. Check that device is within all the specified set value ranges.

5.4 Switching off

1. Shut down device at plant controller.
2. Switch off material flow.
3. Switch off power supply.

5.5 Shutdown

Before shutting the device down for an extended period, the following steps must be taken in accordance with the safety regulations:

- > Switch off device (see chap. "Switching off") and prevent it from being switched back on.
- > Remove material residue from the device.
- > Clean device inside and out. (Observe chapter "Maintenance and servicing")

6 MAINTENANCE AND SERVICING

6.1 Safety instructions



WARNING! RISK OF INJURY!

Improper handling of the device carries the risk of severe personal injury and serious damage. Therefore, servicing and cleaning work must only be carried out by qualified personnel or personnel who have been specially trained in these tasks (training to be documented)!



WARNING! RISK OF INJURY!

Only perform servicing and cleaning work on the device when the device and plant are at a standstill!



WARNING! RISK OF INJURY!

There is a risk that components will be ejected! The spray valve must only be opened after the device has been depressurised and is not operational!

**WARNING! DANGER FROM MATERIAL AND SUBSTANCES!**

There is a risk of coming into contact with or absorbing coating substances and/or cleaning fluids. There is also a risk of inhaling fumes from fluids. Under some circumstances, this can cause lasting damage.

Always wear personal protective equipment when working on the device!

Make sure there is enough forced or natural ventilation.

Obtain medical advice if symptoms are noted!

**WARNING! DANGER!**

The pressure spring inside the spray mechanism of the spray gun is compressed, and can be ejected from the spray gun during maintenance or cleaning work.

6.2 Cleaning

The spray valve must be cleaned when

- > it is soiled by use
- > a different material is to be used
- > wearing parts have to be replaced.

This applies in particular to the nozzle needle, the sealing bush and the nozzle.

! IMPORTANT!

Do not use any sharp edged, metallic aids for external cleaning; only use soft brushes.

NOTE!

Remaining spray media should be dealt with at appropriate time intervals.

6.3 Servicing

The manual spray valve is a high-quality precision device which will usually operate fault-free and without any servicing if handled correctly, provided that only clean, filtered material is used. It is also essential that the control air be clean and, ideally, supplied to the spray valve lightly oiled.

Individual operating conditions and the properties of various materials require a minimum of care to be given to the device.

Before beginning any servicing work:

- > Put on personal protective equipment.
- > Switch off device and prevent it from being switched back on.
- > Switch off pressure plant and prevent it from being switched back on. Depressurise all supply pressure lines and disconnect them from the device.

NOTE!

The device should be checked regularly for wear. It is not possible to specify when wear and tear may occur, since this depends on the material being processed, the switching frequency, and the conditions under which the device is used.

! IMPORTANT!

Using spare and wearing parts from third party manufacturers can present risks. Only use original parts or parts approved by the manufacturer!

6.4 Changing the nozzle and nozzle needle

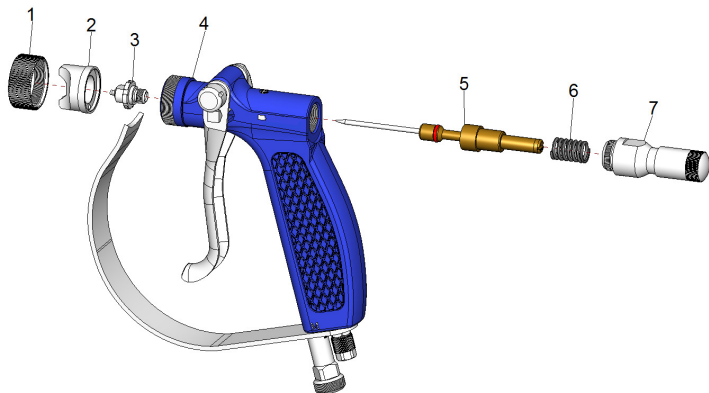

1. Depressurise all connections and stop the material supply!
2. Undo the retaining ring (1) and remove the air cap (2).
3. Undo the locking screw (7) (Caution: The locking screw is under spring tension!)
4. Make sure that the pressure spring (6) does not get lost.
5. Withdraw the nozzle needle (5) and unscrew the nozzle (3).
6. Lightly grease the new nozzle needle (5) and push it into the body of the handle (4). Then remove any remaining grease from the needle tip.
7. Screw the new nozzle (3) into the body of the handle (4).
8. Only now should the locking screw (7) be screwed back onto the body of the handle (4). Make sure that the pressure spring (6) is installed again.
9. Screw the air cap (2) with the retaining ring (1) back onto the body of the handle (4).
10. Perform a functional test of the device after changing the nozzle and needle!

! IMPORTANT!
Always install a new nozzle (3) and nozzle needle (5) at the same time.

NOTE!
When installing nozzles and nozzle needles that have already been in use, they must first be cleaned of all deposits and material residues. Material residues in nozzles can result in leaks in the nozzle needle system, while nozzle needles with hardened material residues can cause damage to the sealing elements in the spray valve.

Installation and maintenance guide

6.5 Replacing and adjusting the nozzle needle

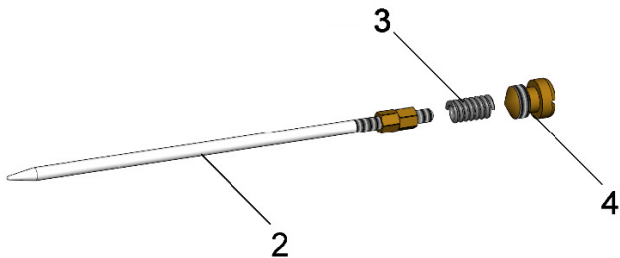

Refer to Chapter 6.2 for removal of the nozzle needle

1. Carefully clamp the nozzle needle between the soft jaws of a vice.
 2. Carefully unscrew the locking screw (4) with a cross-head screwdriver.
(Caution: the locking screw is under spring tension)
 3. Make sure that the pressure spring (3) does not get lost.
 4. Pull the nozzle needle (2) out of the air valve (1).
 5. Push the new nozzle needle (2) into the air valve (1).
- Check that the new nozzle needle is adjusted as in Figure 6.3/1)
6. Push the pressure spring (3) back into the air valve, and then screw the locking screw (4) back on.
 7. Then reassemble as described in Chapter 6.2.

NOTE!

When clamping the needle into the vice, make certain that only soft jaws are used. Otherwise, very slight damage (e.g. streaks or scoring) to the needle can occur, and this could result in leaks at the gland seal.

6.5.1 Adjusting the needle

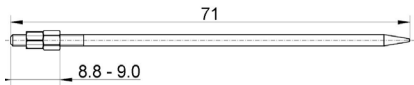

Adjusting the nozzle needle with normal seal and fixed stroke seal:

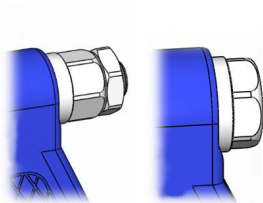

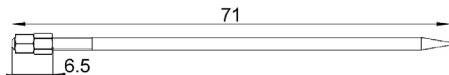

Adjusting the nozzle needle with W3 regulation seal:

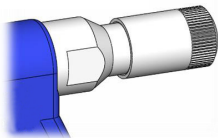

7 FAULTS

7.1 General and safety instructions in relation to faults

Mechanical or pneumatic faults must be rectified by personnel trained and qualified in the relevant area. The manufacturer must be informed of faults which cannot be rectified by the measures described.

7.2 In the event of a fault

In case of faults which pose an immediate risk for persons, property and/or the safe operation of the device or plant:

> Stop device immediately at the EMERGENCY-OFF switch.

In case of faults which do not pose an immediate risk of personal injury or property damage:

> Switch off device, machine or plant at the plant controller.

> Prevent device, machine or plant from being switched back on.

> Inform operator of fault immediately.

> Have qualified personnel identify the type and cause of the fault.

> Have qualified personnel rectify the fault.









WARNING! RISK OF INJURY!

Improper, incorrect work on the device, machine or plant poses serious risks of personal injury and/or damage. Therefore, only trained qualified personnel may correct faults.

The notices and safety rules in chapter "Maintenance and servicing" must be observed before, during and after all work to rectify faults!

PROBLEM	POSSIBLE CAUSE	SOLUTION
No material comes out	Nozzle blocked by material	Clean the nozzle and the needle
	Material pressure too low	Check whether sufficient material pressure is being applied to the spray valve (see "Parameters")
Incorrect spray pattern	Air cap oiled	Clean the air cap
	Incorrect air ratio	See "Spray patterns/types of problem"
Material leakage at the lever	Leaks at the gland seal, worn or faulty gland seal	Exchange/replace the gland seal

7.3 Spray patterns/types of problem

SPRAY PATTERN	PROBLEM	CAUSE	SOLUTION
	Normal spray pattern (flat spray pattern)		
	Normal spray pattern (round spray pattern)		
	Top-heavy or bottom-heavy spray pattern	Dirty air cap Dirty nozzle	Clean nozzles
	Banana-shaped spray pattern	Dirty air cap Dirty nozzle	Clean nozzles
	Centre-heavy spray pattern	Too much material Material too thick	Reduce material flow Thin down material
	Split spray pattern	Too little material Flat spray pressure too high	Increase material flow Increase round spray pressure

8 DIMENSION

8.1 DAS 200 Dimensions

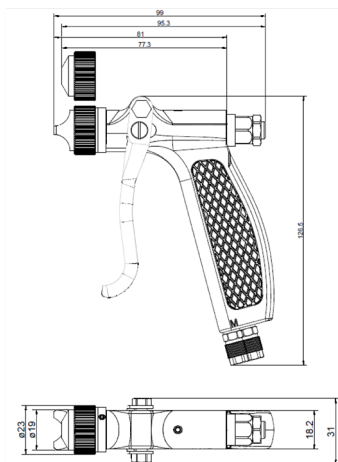

8.2 DAS 200 HP Dimensions

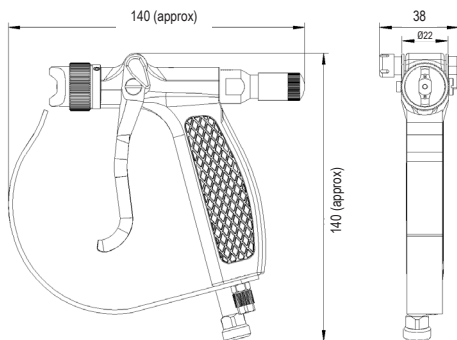

Installation and maintenance guide

9 SPARE PARTS

9.1 Spare parts DAS 200

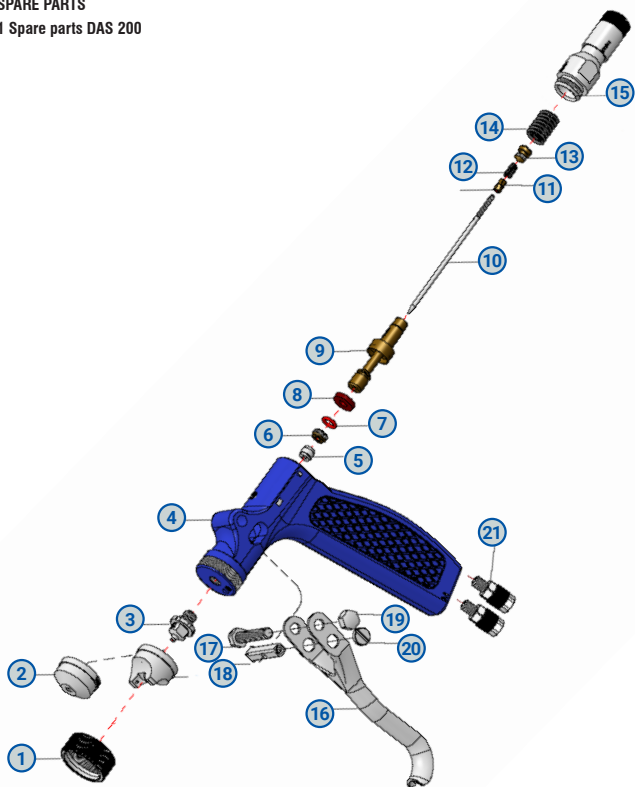

9.2 Spare parts list DAS 200

Ref.	Description	Code
1	COLLAR	110028
2	AIR CAP	vedi tabella successiva
3	NOZZLE DAS-200	vedi tabella successiva
4	MAIN BODY DAS-200	510010
5	NEEDLE SEAL	640062
6	NEEDLE SEAL	810002
7	O-RING	640036
8	AIR VALVE SEAL	640008
9	AIR VALVE	380009
10	NEEDLE	vedi tabella successiva
11	NEEDLE NUT (X1 PC)	410026
12	SPRING	820181
13	LOCKER SCREW	610001
14	PRESSURE SPRING	820024
15	MICROMETRIC REGULATION COMPLETE	800087
16	HANDLE LEVER	190006
17	HANDLE SCREW	610036
18	HANDLE NEEDLE GUIDE	320002
19	HANDLE SCREW NUT	410013
20	NEEDLE GUIDE SCREW	610035
21	AIR FITTING	220021
	GASKET KIT COMPLETE	GASKETKIT-DAS200

Installation and maintenance guide

9.3 Spare parts DAS 200 HP

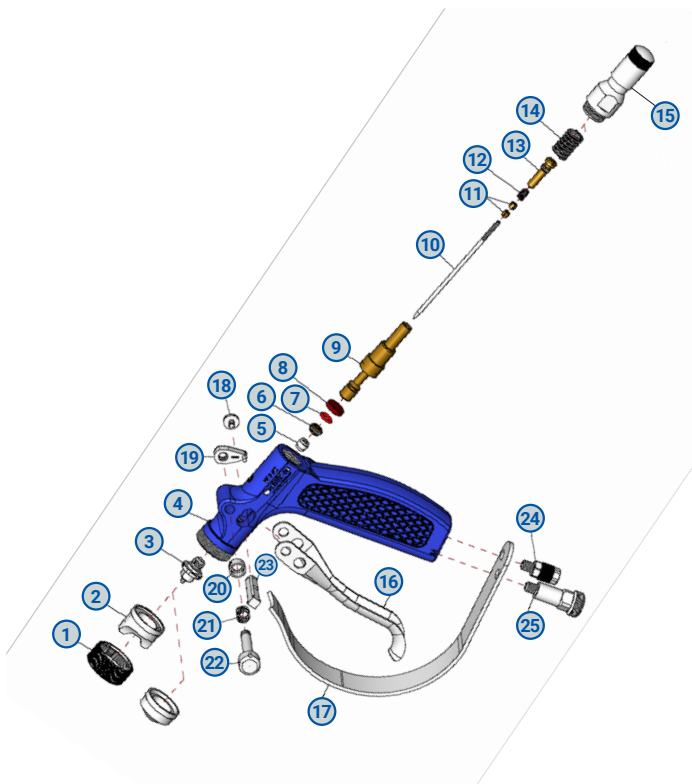

9.4 Spare parts list DAS 200 HP

Ref.	Description	Code
1	COLLAR	110028
2	AIR CAP	vedi tabella successiva
3	NOZZLE DAS-200	vedi tabella successiva
4	MAIN BODY DAS-200	510010
5	NEEDLE SEAL	640062
6	NEEDLE SEAL	810002
7	O-RING	640036
8	AIR VALVE SEAL	640008
9	AIR VALVE	380009
10	NEEDLE	vedi tabella successiva
11	NEEDLE NUT (X1 PC)	410026
12	SPRING	820181
13	LOCKER SCREW	610001
14	PRESSURE SPRING	820024
15	MICROMETRIC REGULATION COMPLETE	800087
16	HANDLE LEVER	190006
17	HANDLE PROTECTION	501424
18	HANDLE SCREW	610035
19	HANDLE LEVER LOCKER	190038
20	HANDLE SPRING BEARING	930675
21	HANLDE SPRING	820182
22	HANDLE PIN	321223
23	HANDLE NEEDLE GUIDE	320002
24	AIR FITTING	220021
25	INLET FITTING M5 - M1/4" GAS	220205
	GASKET KIT COMPLETE	GASKETKIT-DAS200

Installation and maintenance guide

9.5 Needle



Code	Description
110073	NEEDLE 0,2/0,3 MM
110074	NEEDLE 0,5 MM
110075	NEEDLE 0,8 MM
110076	NEEDLE 1,0 MM
110077	NEEDLE 1,2 MM
110078	NEEDLE 1,5 MM

9.6 Nozzle

STANDARD NOZZLE

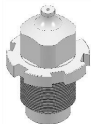

Code	Description
210069	NOZZLE 0,2 MM
210063	NOZZLE 0,3 MM
210064	NOZZLE 0,5 MM
210065	NOZZLE 0,8 MM
210067	NOZZLE 1,2 MM

SPIN NOZZLE

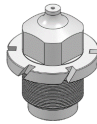

Code	Description
211193	NOZZLE 0,2 MM
210075	NOZZLE 0,3 MM
210076	NOZZLE 0,5 MM
210967	NOZZLE 0,8 MM
210606	NOZZLE 1,5 MM

9.7 Air cap

FLAT AIR CAP

60° (STANDARD)

Code	Description
310032	FOR NOZZLE 0,2-1,0 MM
310033	FOR NOZZLE 1,2-1,5 MM
310079	FOR NOZZLE 1,8-2,0 MM

90°

Code	Description
310036	FOR NOZZLE 0,2-1,0 MM
310037	FOR NOZZLE 1,2-1,5 MM
310166	FOR NOZZLE 1,8-2,0 MM

45°

Code	Description
310038	FOR NOZZLE 0,2-1,0 MM
310039	FOR NOZZLE 1,2-1,5 MM

ROUND AIR CAP

15° (STANDARD)

Code	Description
310034	FOR NOZZLE 0,2-1,0 MM
310035	FOR NOZZLE 1,2-1,5 MM
310080	FOR NOZZLE 1,8-2,0 MM

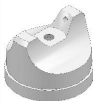

FLAT AIR CAP



ROUND AIR CAP

DAV TECH SRL Via Ravizza, 30 - 36075 Montecchio Maggiore (VI) - ITALY - Tel. 0039 0444 574510 - Fax 0039 0444 574324

davtech@davtech.it - www.davtech.it

We reserve the right to modify at any time, without notice, the specifications, dimensions and weights in this manual.
The illustrations are not binding.