

## SPRAY VALVE

# DAS 100

### DAV Tech Sas

Via S. Pio X 6/a 36077 Altavilla Vicentina (VI)  
e-mail: [davtech@davtech.it](mailto:davtech@davtech.it)      [www.davtech.it](http://www.davtech.it)

# TABLE OF CONTENTS

## 1 INTRODUCTION

- 1.1 Instruction manual
- 1.2 Warranty
- 1.3 Good check
- 1.4 Application field

## 2 SAFETY NORMS

- 2.1 Terms explanation
- 2.2 Symbol explanation
- 2.3 Proper use
- 2.4 Valve installation
- 2.5 Valve use
- 2.6 Valve maintenance
- 2.7 Fluid handling

## 3 TECHNICAL DESCRIPTION

- 3.1 Valve description
- 3.2 Technical data

## 4 INSTALLATION

- 4.1 Valve mounting
- 4.2 Azionare la pistola
- 4.3 Installation diagram
- 4.4 Material connection

## 5 REGOLAZIONI DELLA PISTOLA

- 5.1 Needle adjustment
- 5.2 Fluid quantity

## **6 MAINTENANCE**

- 6.1 General norms
- 6.2 Maintenance program
- 6.3 Nozzle cleaning / replacement
- 6.4 Valve disassembly
- 6.5 Valve mounting

## **7 TROUBLE SHOOTING**

- 7.1 Trouble shooting and what to do
- 7.2 Atomizing regulation

## **8 WARRANTY AND REPAIR**

- 8.1 Warranty
- 8.2 Repair

## **9 DIMENSIONS**

## **10 PART LIST**

- 10.1 Part list
- 10.2 Valve parts
- 10.3 Models

# **1 INTRODUCTION**

## **.1 Instruction manual**

The instruction manual is a part of the valve and it has to be kept in good condition.

Read the manual before installation and maintenance.

Keep the manual at hand for any consultation.

User has to know the content of this manual.

It is forbidden to copy or reproduce totally or partially this manual without DAV Tech written approval.

Text and figures are not a commitment for DAV Tech, that keep the right to change them for modification or improvement of the product.

## **1.2 Warranty**

Warranty includes the replacement or reparation free of charge of all the parts that under normal use and service proves defective in material or workmanship.

## **1.3 Good check**

Do not change or modify the original configuration of the valve.

As you get the good, please check that:

- Packaging is not damage
- The good is exactly the ordered one

## **1.4 Application fields**

- Packaging machines
- Assembly machines
- Paper collating/convertng
- Carton box maker
- Printing machines
- Food industry

**Manufacturer:**

DAV Tech Sas Via S. Pio X 6/a

36077 Altavilla Vicentina (VI) ITALY

e-mail: [davtech@davtech.it](mailto:davtech@davtech.it) [www.davtech.it](http://www.davtech.it)

**NOTE**

We thank you for your attention and you are invited to report to us any recommendation, suggestions or mistakes that can occur by using our products.

## 2 SAFETY NORMS

This instruction manual gives you all information to prevent accidents and a safety use of the products.

### 2.1 Terms explanation

Here below you will find the terms used on this manual.

#### **Intended purpose**

The term 'intended purpose' refers to such a use as can be concluded from the details given by the manufacturer. 'Intended purpose' can also mean such a use as would be seen as common on account of the design, construction and function.

#### **Secondary hazard**

A 'secondary hazard' is a danger that is not obvious and ensues from the use itself of the machine. Secondary hazards are unavoidable despite all the preventive measures that have been taken.

#### **Competent personnel**

A person is competent when he has acquired sufficient knowledge in a special field either by vocational training or experience. A competent person must also be familiar with the specific regulations for safety at work and prevention of accidents and with the generally acknowledged technical rules.

#### **Instructed personnel**

A person is instructed when he has been informed by a competent person about the tasks he is meant to do and the risks ensuing from improper behavior and, if necessary, has received the required training. In addition, an instructed person has been taught about necessary safety devices and protective measures.

#### **Qualified personnel**

A qualified person is a competent person or a sufficiently instructed person.

## 2.2 Symbols explanation



**CAUTION**



**DISCONNECT FROM LINE VOLTAGE**

## 2.3 Proper use

The DAS 100 spray valve is produced following the safety rules.

The DAS 100 spray valve has to be used only with water base fluid or other compatible fluids with a maximum pressure of 8 bar.

Only qualified persons are authorized to install the valve.

Before installation and use the valve read carefully this instruction manual.

Use DAS 100 spray valve only in the field application written in this manual, respect all parameter and data written on this manual.

All other use has to be considering not proper.

## 2.4 Valve installation

Before the installation and use of the valve this manual has to be read and understood.

Keep this manual in a place easy to reach for the operator.



Electrical connection has to follow the safety rules and done by a qualified person.



Before the connection of the fluid pipe be sure that the pressure is off.

## 2.5 Valve use

During valve operation follow the safety rules of this kind of application.

## 2.6 Valve maintenance



All the maintenance operations has to be done by a qualified person and after that the power is off and the fluid pressure discharged.

To clean the nozzle use only cleaning needle supplied from the valve producer.

Using other sharp tool the nozzle can be damage.

Use only original spare parts.

## 2.7 Valve handling

- To use the DAS 100 apray valve with water base fluid check the following points:

The fluid viscosity is into range that the valve can handle.

Fluid is suitable for the use you need.

Fluid data sheet supplied by the fluid producer has all the information as: viscosity, application, shelf life and gluing time.

This data sheet has to be required to the fluid producer.

### 3 TECHNICAL DESCRIPTION

#### 3.1 Valve description

Spray valve DAS 100 is projected to be used in various kind of applications. It can be used in all cases in which you need to spray a fluid.

DAS 100 valve can dispense and spray fluids from low to middle density.

The valve has to be driven with external electrovalves.

The DAS 100 valve is strong and compact and its nozzle and air cap are covered by a teflon surface treatment.

With particular gasket it could be used with solvent.

#### 3.2 Technical data

Material pressure	Max 8 bar
Working pressure	4...6 bar
Atomizing pressure	0,5...2,5
Nozzle size	0.3 – 0.5 – 0.8 – 1.0 – 1.5 mm

## 4 INSTALLATION

### 4.1 Valve mounting

The DAS 100 spray valve has to be fixed on a proper bracket by using the fixing hole on the valve body.

The fixing bracket has to be proper to avoid vibration and displacement. The valve position has to be easy to reach to adjust and clean the valve.



The better working position of the valve is the nozzle vertical down, it is possible to tilt the valve of +/- 45°. For other different position contact DAV Tech.

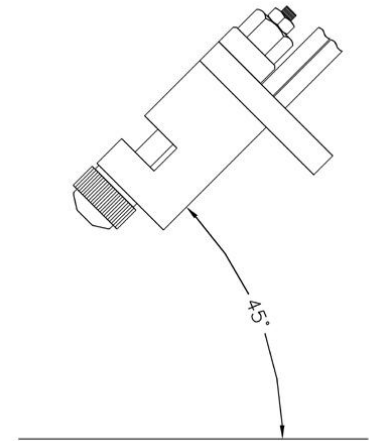

### 4.2 Drive the valve

The DAS 100 valve have to be driven **with 2 separated electrovalves**; one 3/2 for the piston opening (black tube) and one 2/2 for the spraying (blue tube).

Opening piston pressure have to be in tha range between 4 bar and 6 bar.

Spray pressure have to be in the range between 0,5 bar and 2,5 bar.

Spray pressure have to be activate and closed after the opening piston air to prevent any dripping or contamination of the nozzle.

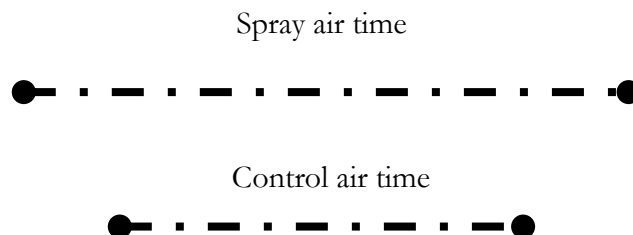

### 4.3 Installation diagram

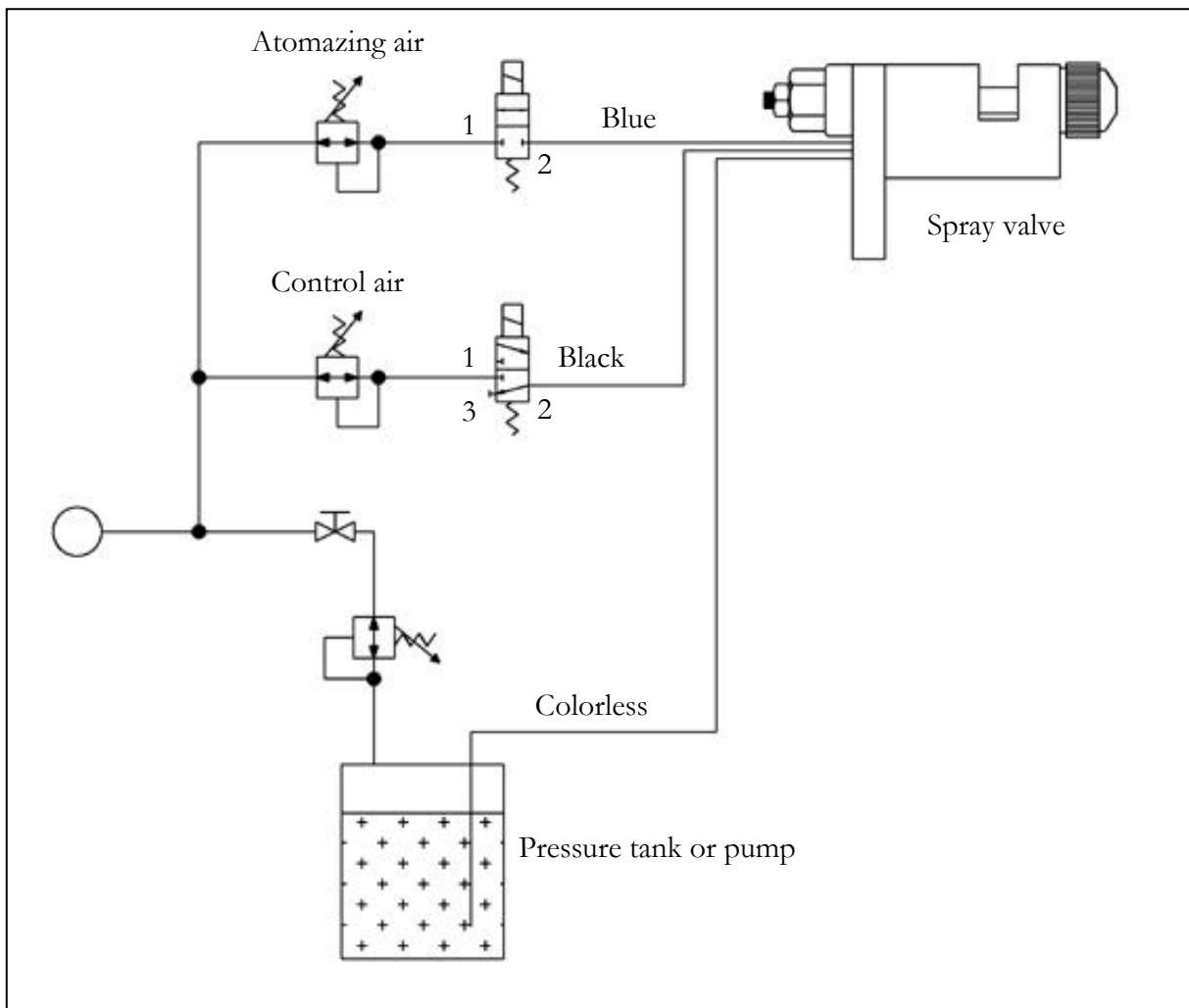

### 4.4 Fluid connection

The valve has to be connected to a feeding unit with the colorless 6x4 plastic pipe

## 5 VALVE ADJUSTMENT

### 5.1 Needle adjustment

By the adjustment of the needle stroke is possible to adjust the fluid quantity.

#### ➤ Screw regulation version:

Unscrew, with a 10mm wrench, locking nut placed on back side of the valve and operate on the adjustment screw with an allen key 3mm.

By turning the adjustment screw clockwise the needle stroke will get shorter so the fluid quantity will decrease, and turning full down the needle close complete the valve.

By turning the adjustment screw anti-clockwise the needle stroke will be longer so the fluid quantity will increase.

Once the adjustment is setted lock the adjustment screw by the nut using the 10mm wrench

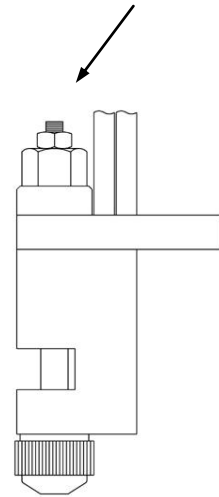

#### ➤ Micrometric adjustment version:

To set the needle stroke turn the adjustment knob placed on the back of the valve.

Turn clockwise to reduce the flow or anti-clockwise to increase the flow.

By turning the knob fully clock wise the valve is close so no fluid will be dispensed.

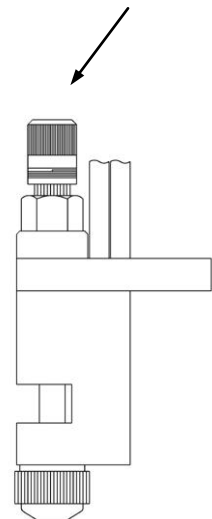



Do not tight the adjustment too much or it will damage the needle and the nozzle.

## 5.2 Fluid quantity

The fluid quantity is adjusted by the following points:

- Nozzle diameter (0.3 - 0.5 – 0.8 – 1.0 – 1.5)
- Fluid pressure
- Needle stroke

By changing these points is possible to get the needed quantity.

## 6 MAINTENANCE

### 6.1 General norms

The DAS 100 valve is designed for high performance and an easy maintenance.



To clean the valve do not use sharp tools but soft brush or rags.

All maintenance interventions has to be done by qualified persons and after the cut off of power and fluid pressure discharge.

To clean nozzle orifice use cleaning needle supplied by the manufacturer.

Use only original spare parts.

The valve has to be washed only with water.

Every evening put a little bit of grease on the nozzle tip.

## 6.2 Maintenance program

	Time	What to do
1	Every day before start	<ul style="list-style-type: none"> <li>- Make a valve test</li> <li>- Clean valve with a wet rag</li> </ul>
2	Every day at the end of production	<ul style="list-style-type: none"> <li>- Make valve test</li> <li>- Clean valve with a wet rag</li> <li>- Put some grease on nozzle tip</li> </ul>
3	Before a stop longer than two weeks	<ul style="list-style-type: none"> <li>- Drain the fluid from the system and wash with water</li> <li>- Leave the system with the water inside</li> </ul>
4	After a stop of two or more weeks	<ul style="list-style-type: none"> <li>- Drain the water from the system and fill it with fluid</li> </ul>
5	Every month or 2000 working hours	<ul style="list-style-type: none"> <li>- As point 3 and 4</li> </ul>
6	Every year or 4000 working hours	<ul style="list-style-type: none"> <li>- As point 3 and 4</li> <li>- Replace wearing parts</li> </ul>

### 6.3 Nozzle clearing / replacement

Before the valve disassembly make following operations:

- Wash the valve with water
- Release pressure into the system
- Unscrew the ring nut and move the air cap
- Unscrew the passage regulation moving it anticlock wise
- Unscrew the nozzle (Pos.2) with 6 mm wrench

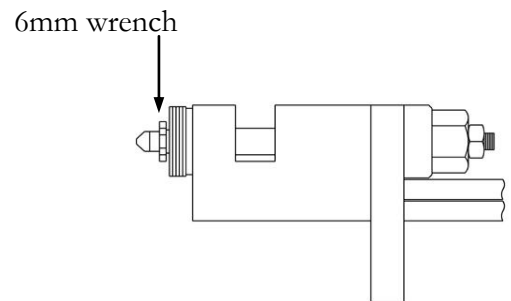

After nozzle disassembly:

- Put the nozzle under the water and then dry it with compressed air, then clean the nozzle hole with a needle
- Repeat the operation until the nozzle hole are clean
- Screw the nozzle (pos.2) with the wrench.

### 6.3 Valve disassemblation

Before the valve disassembly :

- Clean the valve with water
- Release pressure into the system
- Unscrew the ring nut (Pos.3) and move the air cap(Pos.1a – 1b).

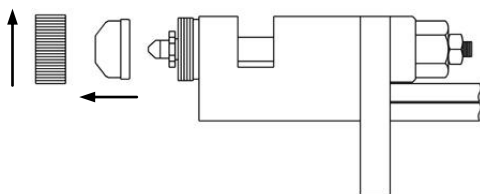

- Unscrew the nozzle (Pos.2) with a 6 mm wrench.

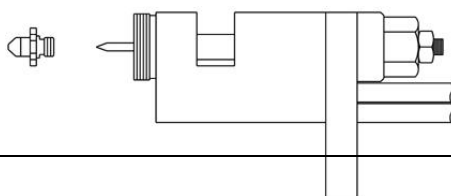

- Unscrew the regulation part (Pos.17a – 17b) with a 17 mm wrench. Pay attention to the spring that is compressed.
- Move the spring (Pos.15)
- Remove with attention the fixing plate (Pos.16) with tubes and tubes holders.

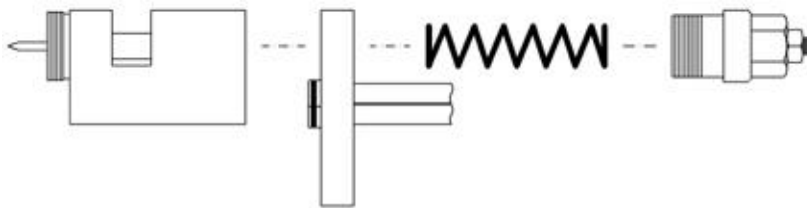

- With a little gripper move out the needle (Pos.9)

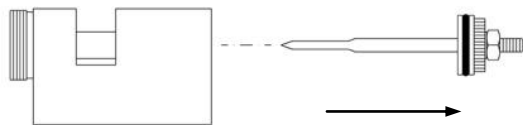

- Unscrew the lock bush (Pos.7) with a 12 mm tube wrench and remove it from the valve body

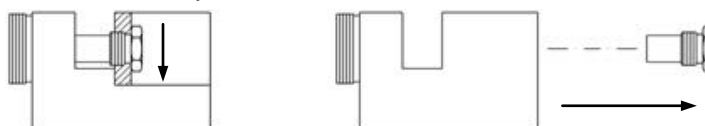

- If necessary disassemble the needle (Pos.9):
- Move the piston, block the ring nut (Pos.12) with a gripper and unscrew the nut on the needle (Pos.11) with a 9 mm wrench and then unscrew manually the ring nut (Pos.12)





The distance between the tip of the needle and the ring nut have to be 57.5 mm



- Check the O-rings (Pos.8 e 14) and if necessary change them.
- Lubricate new O-rings before mounting.

## 6.4 Valve Assembly

- Remove dry fluid from the valve with a wet rag
- Clean very well the nozzle using warm water and blow with compressed air and clean the nozzle orifice.
- Lubricate the O-ring.
- Insert the apposite gasket (Pos.5) and the O-ring (Pos.6) in the valve's body, paying attention mounting the gasket in the right side

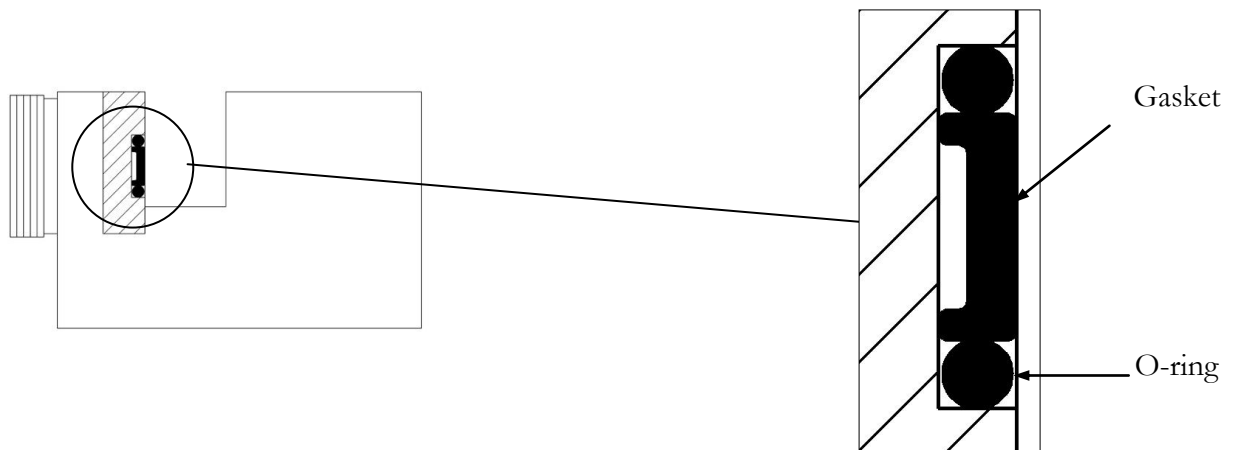

- Screw the lock bush (Pos.7) with a 12 mm tube wrench.

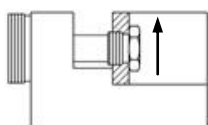

- Insert the needle (complete) (Pos.9).

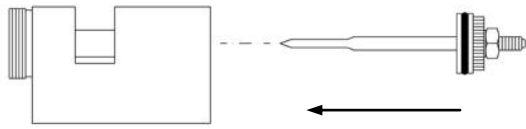

The distance between the tip of the needle and the ring nut have to be 57.5 mm

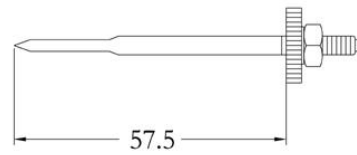

- Screw the nozzle (Pos.2) with a 6 mm wrench.

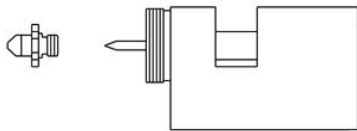

- Mount the fixing plate (Pos.16) with tubes, insert the spring (Pos.15) and screw the regulator (Pos.17a – 17b) with a 17 mm wrench.

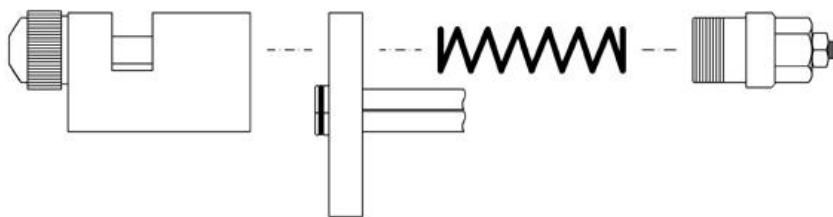

## 7 TROUBLE SHOOTING

### 7.1 Trouble shooting and what to do

Trouble shooting and what to do has to be done only by qualify person.

<b>Difetto</b>	<b>Possibile causa</b>	<b>Intervento da effettuare</b>
No fluid or too less fluid	The valve don't receive the input	Check the input (electrovalve) of the valve and then test it manually.
	Fluid with no pressure or low pressure	Check the pressure of the feeding system and maybe increase it.
	Nozzle is clogged	Unscrew and clean the nozzle
	Filter is dirty (if present)	Wash or change the filter.
	A tube is bend	Check the tubes
	Pressure of opening too low	Check opening pressure (4...6 bar)
	Dry fluid into the system	Clean the system
Fluid dripping from lock bush	O-ring or/and gasket damaged	Change o-ring and gasket
Fluid dripping from valve body and fixing plate	O-ring on the tube holder damaged	Change the o-ring
Fluid dripping also when the valve is not open	Damaged nozzle or dirty nozzle	Clean or change the nozzle.
The valve open with delay	Too low action pressure	Check the opening pressure (4...6 bar)
	O-ring on the needle damaged	Change needle o-ring
Not regular dispensing	Too low spray pressure	Check and move the spray pressure (0,5...2,5 bar)
	Dirt on air cap	Clean the air cap

## 7.2 Spray regulation

- Air cap dirty: Clean the air cap and the nozzle  
Decrease the spraying air

Too much fluid  
Decrease the fluid pressure

Rounded Cap

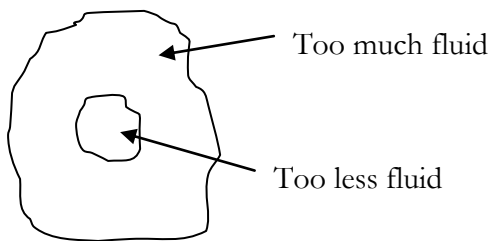

Elliptical cap

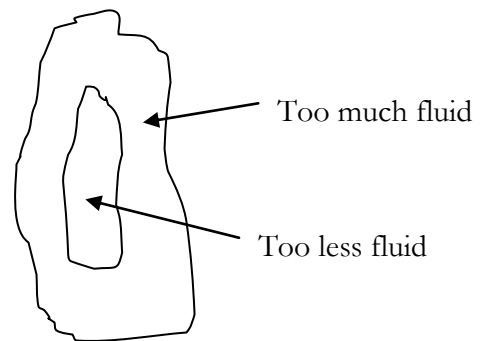

- Irregular application: Not sufficient spray air pressure  
Increase the pressure of the spray air

Too less fluid  
Increase the pressure of the fluid

Rounded cap

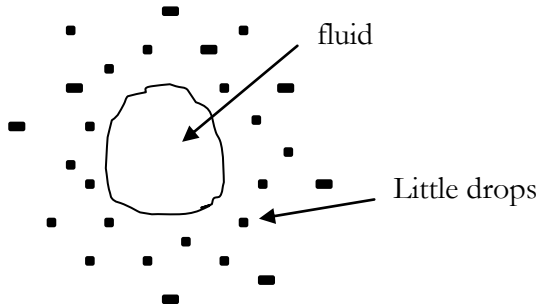

Elliptical cap

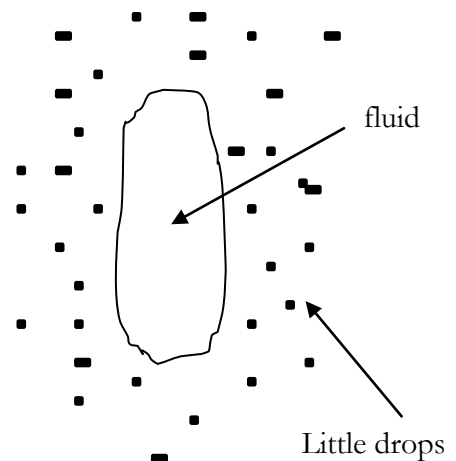

- With : Sufficient amount of fluid
- Right distance between valve and object to spray
- Fluid with no impurities
- Right pressure regulations

The dispensino appare in this way:

Rounded Cap

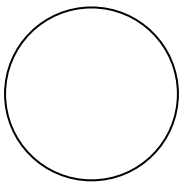

Elliptical Cap

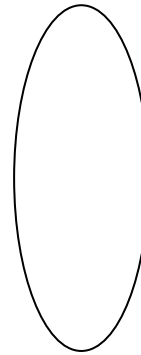

## **8 WARRANTY AND REPARATIONS**

### **8.1 Warranty**

Warranty cover normal application and problems due to material or assembly errors.

Warranty not cover application out of our authorization, using of unofficials spare parts, disassembly by not skilled operators.

Warranty not cover consumable parts.

### **8.2 Reparations**

Reparations have to be done only by skilled operators using only originals spare parts.

## 9 DIMENSIONS

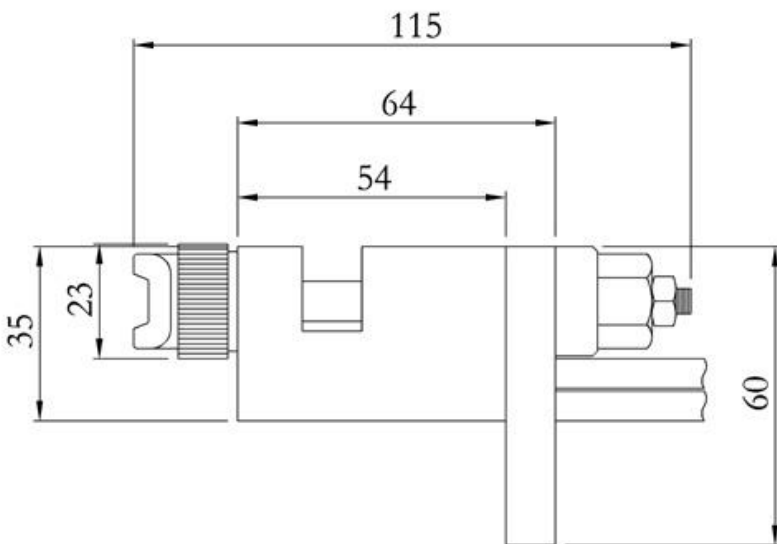
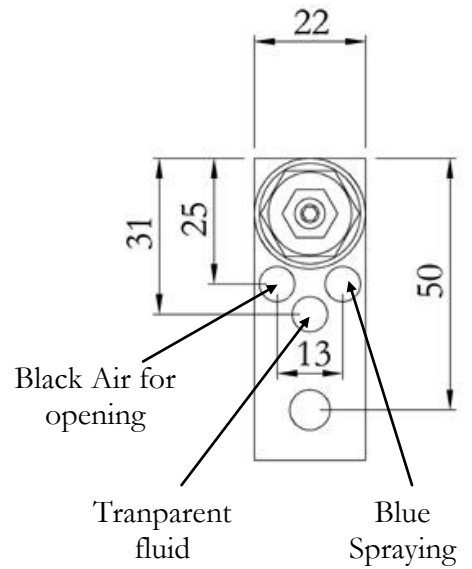
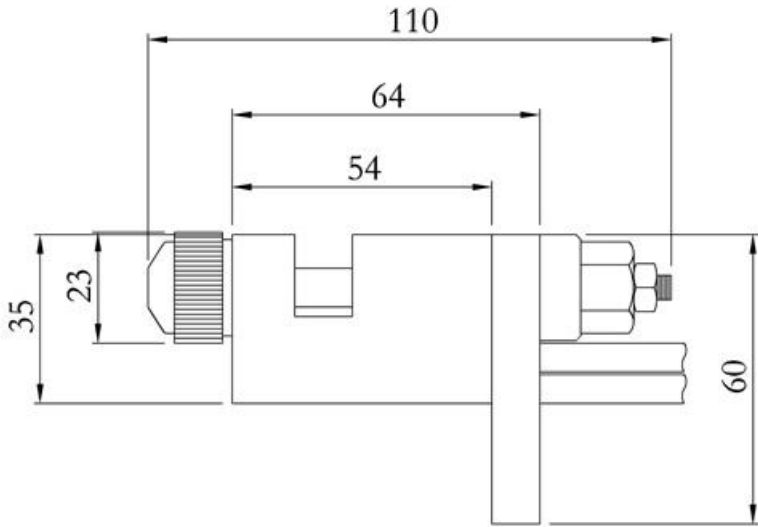

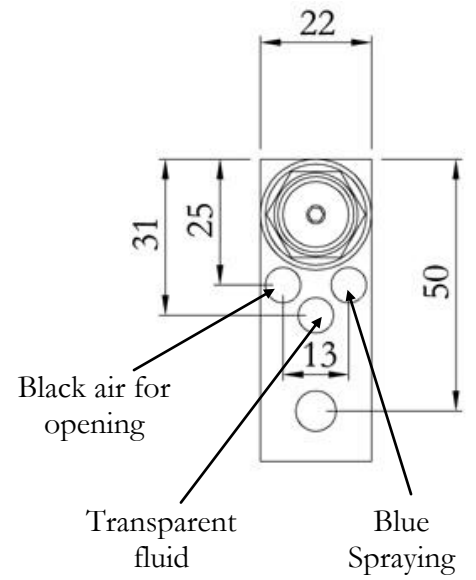
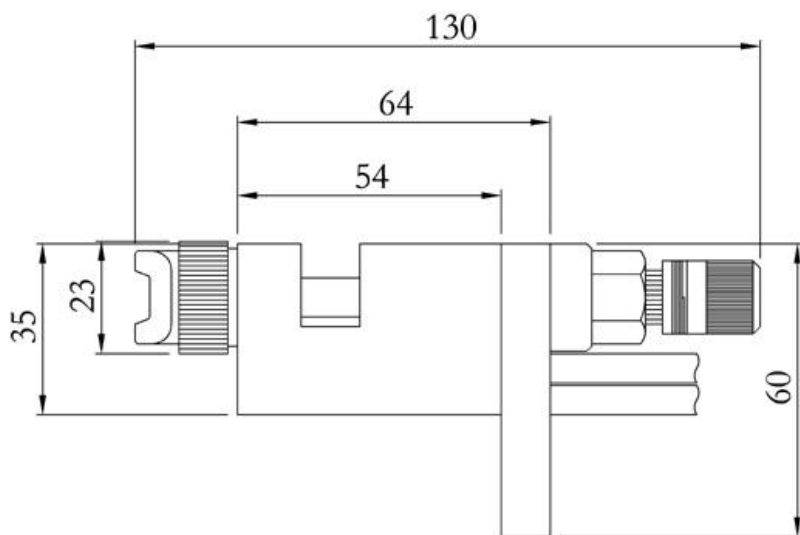
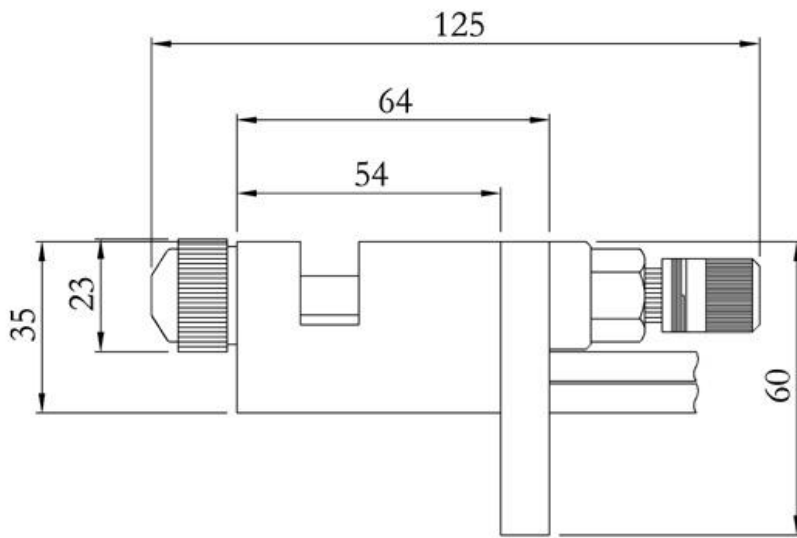

# 10 ESPLOSO

## 10.1 Breakdown

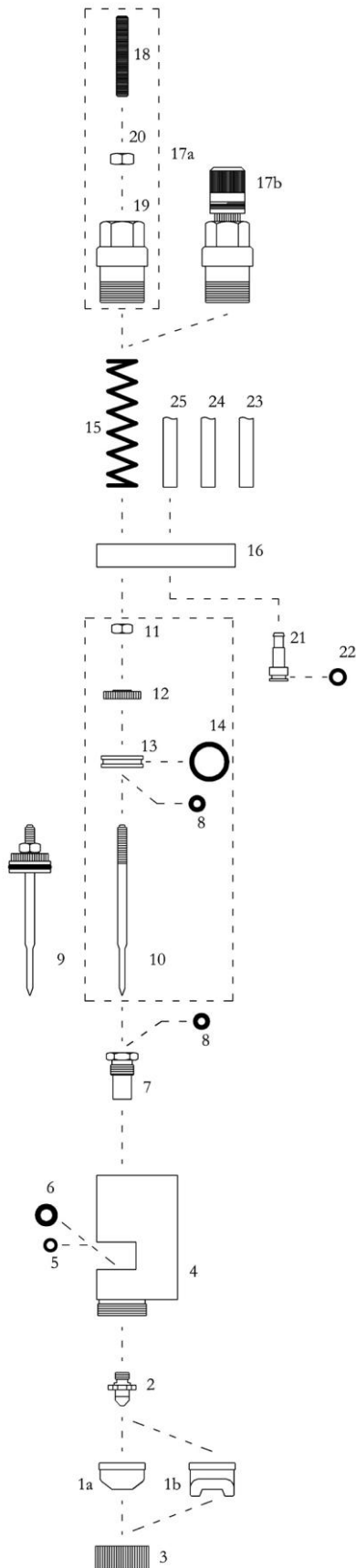

## 10.2 Part list

Pos.	Code	Q.ty	Description
1a	H85792110	1	Rounded air cap teflonated 0.5 – 1.0
	H85792115	1	Rounded air cap teflonated 1.5
1b	H85792210	1	Flat air cap teflonated 0.5
	H85792215	1	Flat air cap teflonated 1.5
2	H85731105	1	Teflonated nozzle 0.5
	H85731108	1	Teflonated nozzle 0.8
	H85731110	1	Teflonated nozzle 1.0
	H85731115	1	Teflonated nozzle 1.5
3	H85792001	1	Ring nut
4	C36000001	1	Valve's body
5*	C36000002	1	Gasket
6*	K92010601	1	O-ring
7	C36000003	1	Bush
8*	K92010302	2	O-ring
9	H84150005	1	Complete needle 0.5
	H84150008	1	Complete needle 0.8
	H84150010	1	Complete needle 1.0
	H84150015	1	Complete needle 1.5
10	H84015505	1	Needle 0.5
	H84015508	1	Needle 0.8
	H84015510	1	Needle 1.0
	H84015515	1	Needle 1.5
11	C36000004	1	Nut needle
12	C36000028	1	Ring nut needle
13	C36000005	1	Piston
14*	K92011401	1	O-ring
15	K93511302	1	Spring
16	C36000006	1	Fixing plate
17a	C36000007	1	Screw regulation (complete)
17b	C36000009	1	Micrometric regulation (complete)
18	C36000022	1	Barrel
19	C36000008	1	Blocco regolazione a vite
20	F63700051	1	Nut
21	C36000011	3	Tube holder
22*	K92010403	3	O-ring
23	K95101106	1m	Black tube (air for opening)
24	K95101302	1m	Transparent tube (fluid)
25	K95101105	1m	Blue tube (spraying air)
			Kit o-rings (pos. 5 + 6)
*	K92911500		Kit o-rings

### 10.3 Available models

Code	Description
C36110300	Spray valve DAS 100 06 003 NR 0,3 rounded cap
C36110500	Spray valve DAS 100 06 005 NR 0,5 rounded cap
C36110800	Spray valve DAS 100 06 008 NR 0,8 rounded cap
C36111000	Spray valve DAS 100 06 010 NR 1,0 rounded cap
C36111500	Spray valve DAS 100 06 015 NR 1,5 rounded cap
C36120300	Spray valve DAS 100 07 003 NR 0,3 elliptical cap
C36120500	Spray valve DAS 100 07 005 NR 0,5 elliptical cap
C36120800	Spray valve DAS 100 07 008 NR 0,8 elliptical cap
C36121000	Spray valve DAS 100 07 010 NR 1,0 elliptical cap
C36121500	Spray valve DAS 100 07 015 NR 1,5 elliptical cap
C36130300	Spray valve DAS 100 06 003 RM 0,3 rounded cap
C36130500	Spray valve DAS 100 06 005 RM 0,5 rounded cap
C36130800	Spray valve DAS 100 06 008 RM 0,8 rounded cap
C36131000	Spray valve DAS 100 06 010 RM 1,0 rounded cap
C36131500	Spray valve DAS 100 06 015 RM 1,5 rounded cap
C36140300	Spray valve DAS 100 07 003 RM 0,3 elliptical cap
C36140500	Spray valve DAS 100 07 005 RM 0,5 elliptical cap
C36140800	Spray valve DAS 100 07 008 RM 0,8 elliptical cap
C36141000	Spray valve DAS 100 07 010 RM 1,0 elliptical cap
C36141500	Spray valve DAS 100 07 015 RM 1,5 elliptical cap